

Chambers®

WALL MOUNTED HOOD FANS

MVW102B

** Available in 75 cm (30"), 90 cm (36") Widths



Comes with grey control panel for a monochromatic look

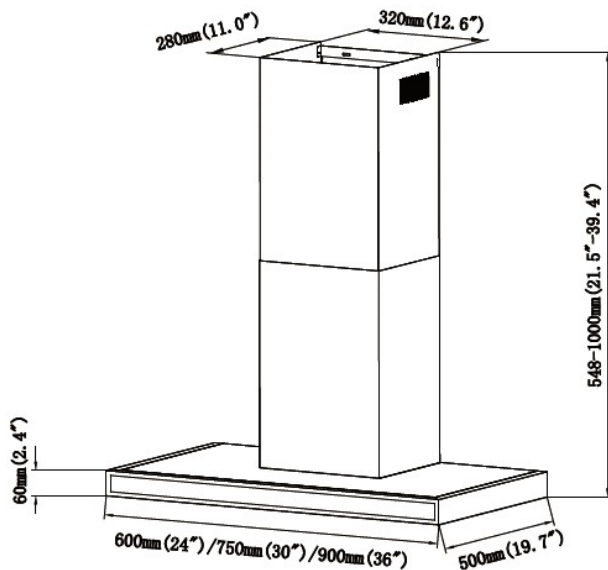

Key Features

- ✓ Durable premium stainless steel
- ✓ No visible brand marks on hood
- ✓ Monochromatic control panel
- ✓ 'Invisible' Touch Sensitive Controls
- ✓ Powerful 600 cfm 3 speed blower
- ✓ Perimeter Venting conceals multi-layer filters
- ✓ Exclusive LED Full Panel Lighting
- ✓ Integrated Heat Sensor to auto-start hood
- ✓ Convertible to ductless option
- ✓ 120V power cord included
- ✓ 6" Duct Transition included
- ✓ Shipped in high burst strength packaging

Warranty

- 3 year limited warranty **

Optional Accessories

- Recirculation kit (CP120)
- 3 dBa noise reducer (JVA-NS1)
- Replacement mesh filters

